

# RASPBERRY Pi BASED IRRIGATION SYSTEM BY USING WIRELESS SENSOR NETWORK AND ZIGBEE PROTOCOL

**K.Nireesha, A.Venkateswara Rao M.Tech,**

*Department Of Electronics Communication and Engineering Sri Sivani Institute Of Technology  
Chilakapalam, Andhra Pradesh, India.*

## ABSTRACT

*In this paper an Irrigation system using wireless sensor network and Raspberry Pi. An Irrigation system was developed to optimize water use for agricultural crops. In this Irrigation system using a wireless sensor network and Embedded Linux board. The system provides a web interface to the user so that we can control and monitor the system. In this paper Raspberry Pi is used as an Embedded Linux board which is designed based on ARM 11 Micro Controller architecture.*

*Initially we need to establish a LAN connection between raspberry pi and users personal system. Apply power supply to the raspberry pi circuit using constant power supply source. Raspberry pi will take 15 minutes for booting process. After completion of booting the raspberry pi will gets ready. For the process of updating of moisture and sensor values from soil it requires internet connection. To monitor the system remotely open internet browsers search the link*

*By login with above id and password user can monitor the irrigation system wirelessly at any distance from anywhere. Then the data will be updated in the server automatically for every second.*

*Keywords— Keywords— wireless sensor network and embedded Linux board, Raspberry Pi processor, ARM11 microcontroller, Zigbee protocol*

## I.INTRODUCTION

Agriculture is the worldwide prime occupation of human being, 64% of total available land is occupied by the agriculture, and it consumes 85 % of available fresh water. This figure of water consumption increases every year due to globalization and population growth. There is a challenge in front of every country to sustain the fresh food requirement and reducing the farm water consumption.

Irrigation is the process of watering the soil. The requirement of water to the soil depends on soil properties like soil moisture and soil temperature. It also depends upon the crop which grows in the soil. From last decade, few existing system working for reducing the agriculture water

consumption, but these systems have some limitations. These systems, watering is done without analyzing the soil properties, due to which systems apply non uniform water to the soil results in less yields. Also systems required more human intervention and time consuming. So we require modern technology to resolve this problem and support better irrigation management. For that we have proposed system which is Web based automatic irrigation system using wireless sensor network and embedded Linux board. The wireless sensor network creates the networks of multiple devices having capable of computation, communication and sensing. It provides a bridge between the real physical world and virtual worlds and having a wide range of potential applications

In this proposed system WSN is consists of two nodes, coordinator node and Router/End device node. Each node mainly consists of memory, processor and an RF transceiver. The coordinator node is based on Raspberry Pi (Rpi) embedded Linux board and End device is based on Arduino UNO Atmega328 platform. The function of the coordinator node in the system is to initiate the communication with distributed End device nodes via the ZigBee wireless communication protocol and continuously collects the soil moisture and soil temperature data and store collected data in the database. The database is created on the raspberry Pi board which is a MySQL database. Coordinate node analyzes the received data and decides the water required for the soil. If the analyzed data shows that water is required, the coordinator node sends commands to water pump controller make Irrigation on. Rpi has an Ethernet interface and it runs a simple data web server. Hence coordinator node allows data collection over ZigBee, and data monitoring and system control from web browser remotely.

## II.AUTOMATED IRRIGATION SYSTEM

### A.Proposed architecture used for automated irrigation

Design of automated irrigation is as shown in Figure.1, Coordinator node manages the multiple Router/End device nodes. The system consists of three parts Coordinator node, Router/End device sensor node and web server design. Coordinator node and End device sensor node is linked by radio transceiver. It will allow transmitting soil parameter data from End device sensor node to coordinator node and controlling signal from coordinator node to water pump node. The wireless communication is based on ZigBee protocol it uses 2.4 GHz wireless link. The web server is designed on Rpi for monitoring and control the irrigation. Any devices which have the capability to access the web service will be used here for monitoring the data like PC, laptop, smartphone etc.

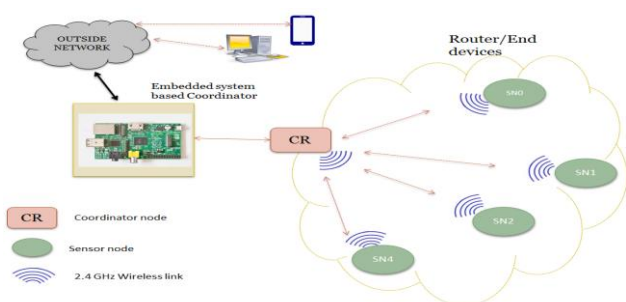

Figure. 1. Architecture of system

### 1) Raspberry Pi

In this proposed system we have used Raspberry Pi as the controller of coordinator node. Rpi is the small, inexpensive minicomputer. It continuously collects the information send by sensor nodes via ZigBee, and processing large quantities of data timely and available for users to view. It is the core of the system.

### 2) End device sensor node

Sensor node used here to sense the soil parameters. It is designed using Arduino UNO microcontroller board based on Atmega 328. It consist of the ZigBee protocol based radio transceiver, power supply unit, soil moisture and soil temperature (DS1822) Sensors, and data logger for temporary storage. It will sense the soil parameter typically at one-minute intervals and send back to the coordinator node via the ZigBee wireless communication protocol.

### 3) ZigBee

A ZigBee protocol for wireless communication which is based on the underlying protocol IEEE 802.15.4, which defines the network physical layer, and controlling layer for media access, while ZigBee protocol defines the network layer, application layer and specifications of the network security services.

### 4) Database and web server

In this proposed system we have designed the database based on MySQL which is installed on Rpi. MySQL is the popular choice of database in a web application. MySQL is the relational database management system (RDBMS). It is open source software. Database stores the soil parameter information send by a sensor node in it with time. It provides the information to the web page for monitoring the system remotely.

### 5.) Sensors

#### a) Soil temperature sensor

The temperature sensor used here is DS1822 digital thermometer with  $\pm 2^{\circ}\text{C}$  accuracy over a  $-10^{\circ}\text{C}$  to  $+85^{\circ}\text{C}$  range. Data is read over a 1 wire serial bus in 2's complement format with 9 to 12 bits of resolution. The DS1822 requires only one data line (and ground) for communication with a central microprocessor. It has an operating temperature range of  $-55^{\circ}\text{C}$  to  $+125^{\circ}\text{C}$ . In addition, the DS1822 can derive power directly from the data line, eliminating the need for an external power supply. Each DS1822 has a unique 64-bit serial code, which allows multiple DS1822s to function

on the 1-Wirebus; thus, it is simple to use one microprocessor to control many DS1822s distributed over a large area. Applications that can benefit from this feature include temperature monitoring systems inside buildings, equipment or machinery, and process monitoring and control.

#### *b) Soil moisture sensor*

The module consists of, detection probe, and sensor board. It is having triple output mode, digital, analog, and serial with exact readings. The sensor will detect the moisture of the soil surrounding it, i.e. shortage of water content of the soil. If the contents are low the module output will be high otherwise the output will remain in neutral conditions. This moisture sensor has two probes used to pass the current into the soil, and then it reads that resistance between two probes to get the moisture level. More water present in the soil makes the soil conduct electricity more easily indicate less resistance, while dry soil having less water conducts electricity poorly indicate more resistance.

#### B. Introduction of Raspberry pi



Figure. 2. Raspberry Pi

The Raspberry Pi is the low cost credit size minicomputer which has recently become popular. The Raspberry is the cheapest low power arm 11 based microcontroller operating at 700MHz frequency and having the 512 megabytes of RAM memory. Figure.2. Shows the picture of Raspberry Pi.

The Raspberry Pi is boot by external memory card with rasbian wheezy images.

Coordinate node contains Xbee transceiver, database, and Web server. It collects the sensor data continuously and stores it in a MySQL database. Two sensor node never transmits the data simultaneously, because the ZigBee protocol having the mechanism of collision detection. The python-serial programming is used in raspberry Pi to open the serial port The web server is designed on the Rpi. It is based on Apache open source software. It provides the web interface to the user to monitor and control the system remotely. The user can access the system status using an internet access device like personal computer, laptop, and smart phone.

### C. Introduction of Arduino UNO



Figure. 3. Arduino UNO R3

The Arduino UNO is the microcontroller board based on ATmega328. It has 14 digital input/output pins, 6 analog inputs, 16MHz ceramic resonator, USB connection, a power jack. Arduino consists of a microcontroller and Integrated Development Environment (IDE). IDE is used to write and upload computer code to the microcontroller. It can be powered by USB cable or power jack of 5v. It contains everything needed to support the microcontroller.

### III. IRRIGATION SYSTEM OPERATION

We deploy the two sensor node separated from each other. The distance between the two nodes depends on the type of soil means if the soil having the same water holding capacity required only one sensor node. Each sensor node contains one soil moisture and soil temperature sensors, and one ZigBee transceiver. The programming on the Arduino board is such way that after every minute sensor node sends soil parameter data to coordinator node via the ZigBee wireless communication protocol. The XBee transceiver device has a unique 64 bit serial address and 16 bit personal area network address (PAN). PAN ID is same for every Xbee device working on the same network. The XBee devices will go to sleep mode after every minute to support minimize power consumption. Flowchart of a Sensor node shown in fig.4

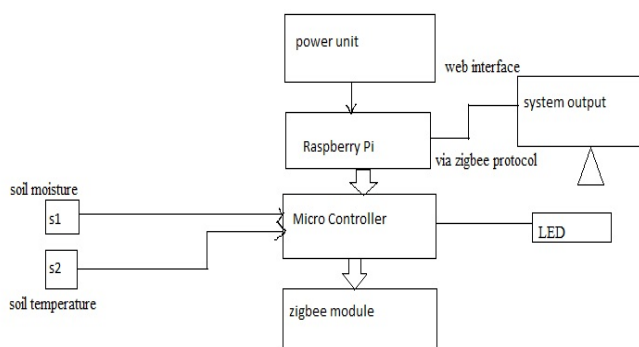

Figure 4: An operating system of Irrigation process by using Raspberry Pi

#### A. Communication

We have used Xbee pro S2 in our system. The Xbee device is obeying the rule of IEEE 802.15.4 wireless communication protocol. It supports the mesh, and point to point network. It's having an indoor/urban 300 ft. (90m) range and outdoor line of sight 3200m range. It supports sleep mode for reducing the power consumption. In our system Rpi connected Xbee device set as coordinator and

sensor connected Xbee device set as an End device. Coordinator node is always running mode while End device after every minute using sleep mode. Xbee device of Water pump node set as a router having the destination address of the coordinator node.

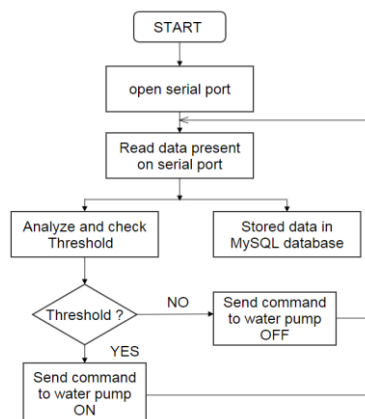

Figure 5: Coordinator node flowchart

#### IV. EXPERIMENTAL TEST RESULTS

First the sensors are deployed in the farm. The distance between the two sensor node is depends on the type of soil.

The combination of Arduino, ZigBee, and moisture sensor is responsible for capturing the moisture present in soil. Depending on the moisture contain and temperature of soil the watering to the crop is given. The soil parameters are stored in database tables and these tables are displayed on the web page using PHP script and web server

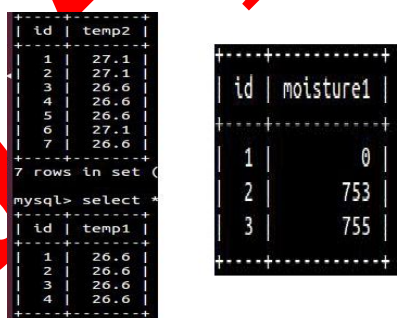
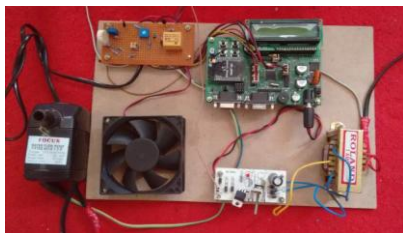

Figure.6 Temperature sensor data stored in MySQL database

The database using MySQL open source software created. In the database we have created two tables for sensor node1 and sensor node2. Temperature data of each sensor are stored in the table shown in figure 6





**Figure 7(a):** Receiver Section



**Figure 7(b):** LAN connection to RPi.

## V. CONCLUSION

This paper designs the automated wireless irrigation system using WSN and embedded Linux board. In this we have used raspberry Pi as an embedded Linux board which allows collecting the sensor information from sensor node continuously, store it in a database and providing the web interface to the user. The system is watering to the crop uniform by analyzing the soil parameters, it will help to reduce the fresh water consumption. By providing the web interface and automation user can easily monitor the system and it will minimize the human intervention. The ZigBee protocol is used here for wireless communication it will create network easily and combination of Arduino, Xbee and sensor create a low power inexpensive sensor node. The Apache web server crated on Raspberry Pi easily displaying the contents of sensor data.

## REFERENCES

- [1] Gutierrez, J.; Villa-Medina, J.F.; Nieto-Garibay, A.; Porta-Gandara, M.A., "Automated Irrigation System Using a Wireless Sensor Network and GPRS Module," *Instrumentation and Measurement, IEEE Transactions on* , vol.63, no.1, pp.166,176, Jan. 2014.
- [2] Yunseop Kim; Evans, R.G.; Iversen, W.M., "Remote Sensing and Control of an Irrigation System Using a Distributed Wireless Sensor Network," *Instrumentation and Measurement, IEEE Transactions on* , vol.57, no.7, pp.1379,1387, July 2008.
- [3] W. A. Jury and H. J. Vaux, "The emerging global water crisis: Managingscarcity and conflict between water users," *Adv. Agronomy*, vol. 95, pp. 1–76, Sep. 2007.
- [4] Mirabella, O.; Brischetto, M., "A Hybrid Wired/Wireless Networking Infrastructure for Greenhouse Management," *Instrumentation and Measurement, IEEE Transactions on* , vol.60, no.2, pp.398,407, Feb.2011.

- [5] Wark, T.; Corke, P.; Sikka, P.; Klingbeil, L.; Ying Guo; Crossman, C.; Valencia, P.; Swain, D.; Bishop-Hurley, G., "Transforming Agriculture through Pervasive Wireless Sensor Networks," *Pervasive Computing, IEEE* , vol.6, no.2, pp.50,57, April-June 2007.
- [6] Rani, M.U.; Kamalesh, S., "Web based service to monitor automatic irrigation system for the agriculture field using sensors," *Advances in Electrical Engineering (ICAEE), 2014 International Conference on* , vol., no., pp.1,5, 9-11 Jan. 2014.
- [7] Genghuang Yang; Yuliang Liu; Li Zhao; Shigang Cui; Qingguo Meng; Chen HongDa, "Automatic irrigation system based on wireless network," *Control and Automation (ICCA), 2010 8th IEEE International Conference on* , vol., no., pp.2120,2125, 9-11 June 2010.
- [8] Zhang Feng, "Research on water-saving irrigation automatic control system based on internet of things," *Electric Information and Control Engineering (ICEICE), 2011 International Conference on* , vol., no., pp.2541,2544, 15-17 April 2011.

IJAER