

APPLICATION OF ROBOTS FOR SMART CROP CULTIVATION IN RURAL COMMUNITY ENVIRONMENTS

***Dr. S.R.BOSELIN PRABHU, ** Dr. E.GAJENDRAN**

**Assistant Professor, Department of Electronics and Communication Engineering,
SVS College of Engineering, Coimbatore, India*

***Professor, Department of Information Technology,
St.Martin's Engineering College, Hyderabad*

ABSTRACT

Indian agriculture, even after the Green Revolution, is not as productive as it could potentially be. It calls for a second Green Revolution—one of “precision agriculture”, where cutting-edge technology is used to maximize production with minimum input costs and resources. In this paper we present a multi-purpose agricultural robot to implement precision irrigation, fertilizer addition and de-weeding, apart from continuous monitoring of crop and soil conditions. This will involve efficient utilization of water resources, intensive plant and soil monitoring, condition based use of fertilizers and the ability to work in unstructured environments. Developed agriculture needs to find new ways to improve efficiency.

Keywords-*Precision agriculture application, agricultural robots, robotic irrigation, robotic de-weeding.*

I. INTRODUCTION

The green revolution changed the very technology that was being applied in the Indian agricultural system. It showed great results and made India agriculturally self sufficient. But these technologies have remained untouched since then and no major improvement has been made to step up productivity to meet the demands of the burgeoning population. The new trend for improvement in agricultural production is that of precision agriculture. Some of the major problems in Indian agriculture are raising input costs, availability of skilled labour, dwindling water resources, over usage of fertilizers and lack of proper crop monitoring. Overcoming some of these problems requires tedious manual work which due to unavailability of enough labour cannot be performed. Hence, one of the solutions could be involving automation technologies in agriculture. Agricultural automation could help farmers single headedly maintain their crops and optimize usage of resources. Here, we present an agricultural robot, capable of implementing some of the methods of precision agriculture such as precision irrigation, soil based application of fertilizers, de-weeding and crop monitoring.



Fig 1: AG robots on the farm

II. PRECISION AGRICULTURE

Precision agriculture involves the adequate and optimum usage of resources based on various parameters governing crop yield. The Handbook of Precision Agriculture [1] defines Precision agriculture as a holistic and environmentally friendly strategy in which farmers can vary input use and cultivation methods – including application of seeds, fertilizers, pesticides and water, variety selection, planting, tillage, harvesting – to match varying soil and crop conditions across a field. It is a management philosophy or an approach to agriculture where critical factors that affect yield are identified, and intrinsic spatial variability is determined. It is essentially more precise farm management made possible by modern technology. The variations occurring in crop or soil properties within a field are noted, mapped and then management actions are taken as a consequence of continued assessment of the spatial variability within that field [8-18].

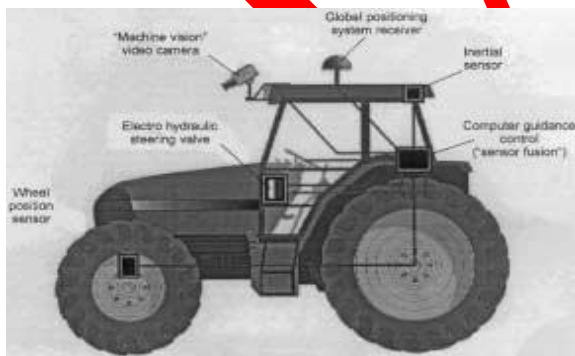

Fig 2: shows that automated harvester

Most of the methodologies of precision agriculture require tedious processes that could only be implemented using machines. De weeding, which was being done manually, is presently mostly dealt with herbicides, which reduces crop yield and degrades soil quality. A single solution to

implement precision agriculture, perform tedious agricultural processes and combat the problems of weeds could enhance agricultural yield to a large extent. In this paper we present a single gantry robot capable of carrying out various precision agriculture related operations. The primary goal of the design would be to implement precision irrigation and soil monitoring on each crop entity in the robot's working envelope, perform de weeding and self structure a cultivated field through accurate robotic crop planning. Crop planning would ensure effective use of the land for maximum yield [19-24].

III. THE GANTRY ROBOTIC SYSTEM

Most of the methodologies involving precision agriculture mostly modify the usage of pivot irrigation systems or drip irrigation systems. Perry and Pocknee [2] in their paper reported on the development of a precision pivot irrigation control systems based on GPS data of a field. But these methods haven't proved to be very effective. The most ideal solution to precision agriculture would be to build a robot that individually waters every crop in the field. Building a terrestrial robot with this ability would be impossible as it would have to maneuver itself along with a water hose. The most effective solution would be to use a gantry robot system.

The gantry [Fig 1] consists of three linear drives to position the robot at any given co-ordinate in its working envelope. A typical plot of agricultural land in India is assumed to be having dimensions of 100x100m. A gantry robot would be an optimum solution for this dimension provided it has a good traversal speed. The linear drive has to be suitable for this speed. The linear drive will also have to be precise enough as only simple sensors are to be used to maintain cost effectiveness. There should be no possibility of slip or backlash in the drive. This robot, along with its fixture can be easily detached and attached to the frame on some other field, enabling sharing of a single robot by many farmers.

Gantry robotic systems used in industries are built robustly and are expensive. Their main advantage is their capability of having a large working environment. They can also be conveniently be used for precision agriculture purpose as maneuvering would not be affected by the water pipe lines. But their costs need to be reduced for feasibility in agriculture. The feasibility can be improved by modifying the linear drives for light pay loads and using cheaper material for the framework. A gantry frame would have to be set up through the length cultivated field, which would be the working envelope of the robot. Normally screw drives or timing belt drives are used in industries for precision linear drives. But these drives cannot be used for agricultural purposes as this application demands the linear drive to be cost effective, extremely fast and applicable for large lengths. We present a cheaper and faster linear drive which would be well suited for applications with lighter payloads.

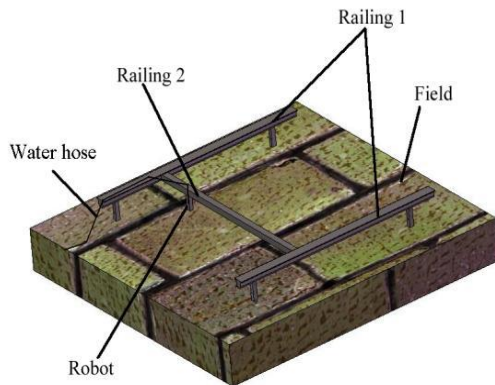

Fig 3: An aerial view of a gantry robot system on a field.

3.1 THE LINEAR DRIVES

3.1.1 HORIZONTAL MOVEMENT

The linear drives used for the horizontal displacements (X-axis and Y-axis displacement) of the gantry robot are essentially a wheel rolling on a rail. Screw drives or belt drives are normally used in an industrial gantry robot to avoid backlash and other positioning related errors. The positioning errors need to be eliminated in this system too as the robot knows its position only through the optical encoders used with the DC motors powering the linear drives. Any slip between the wheel and the rail could lead to serious positional errors. To avoid these errors, peanut shaped projections and engravings are applied on the wheel and the railing respectively [Fig 4]. These projections are made small compared to the wheel that they can be assumed to have a non curved surface. Peanut shaped mating parts are used to avoid slippage and backlash errors between the wheel and the railing. The support rollers arrest any vertical movement of the wheel. The bearing casing holds the shafts of the wheel and the support rollers. This design is aimed at reducing the slippage, and not as a power transmission device.

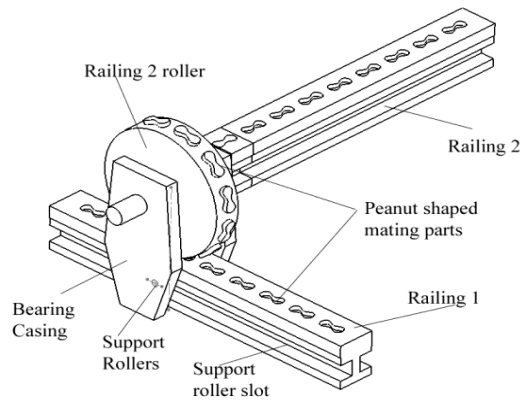

Fig 4A: linear drive used for X & Y axis movement

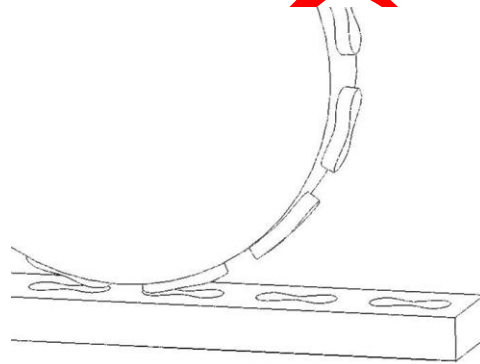

Figure 4B: Zoomed version of railing system

Mating of the profiles on the roller and the railing, The peanut shape used has several advantages. Firstly, they lock easily and tightly, but only in one fixed position. Hence, the wheel will have a constant orientation with respect to the railing. The vertical movement of the wheel is arrested by the support rollers inside the support rollers slot in the railing. Therefore, with the peanut shaped mating projections and engraving any possibility of backlash errors or slippage is avoided. Their profile being convergent contrasts that of circular teeth that are divergent. Secondly, as the beam lengths are going to be very high for this application, stress concentrations at any point on the beam should be minimal. The peanut shape induces lower stress concentration than any other shape due to its close resemblance to elliptical shapes, which create minimum stress concentration. Hence, due to these advantages, the peanut shaped mating parts can be used for the linear drives.

3.1.2 VERTICAL MOVEMENT

The vertical movement of the robot is driven by linear screw drive [Fig 5]. As the traversal length along the Z-axis would be small, screw drives can be used cost effectively. The linear screw drive system is supported on the bearing casing of the wheel moving on railing 2. The robot is provided with a fixture to mate with the screw thread. As the screw thread is rotated by a DC motor with optical encoder, the robot is forced upward or downward. A screw drive support with slots is provided for the robot to grip on to avoid rotating during the rotation of the screw thread. The clockwise or anticlockwise rotation of the screw thread determines the upward or downward movement of the robot.

3.2 THE WATER FLOW

The robot has to be connected to an overhead water supply applying the water for the crops. A hose from the water tank is connected to the robot. The hose is supported on the framework of the gantry itself. This does not hinder the movement of the robot. The water rate is controlled by a timer which opens a valve for a definite time depending on the moisture requirements of the soil at a particular co-ordinate. Fig. 5 explains the flow and control of the water by the robot. The robot gets its positional details from the optical encoders mounted on the motor shafts of the linear drives. From the co-ordinate detail, the robot finds the moisture requirement of the soil at that co-ordinate [25-28].

The water outlet solenoid valve is then opened for an appropriate time. The screw rod is enclosed in a screw drive support with slot on which the robot system grips to avoid rotating due to the rotation of the screw thread. The robot system has a water inlet valve to which the water hose is connected. It also has an attachment joint for auxiliary attachments such as the de weeding attachment. The screw rod is enclosed in a screw drive support with slot on which the robot system grips to avoid rotating due to the rotation of the screw thread. The robot system has a water inlet valve to which the water hose is connected. It also has an attachment joint for auxiliary attachments such as the de weeding attachment.

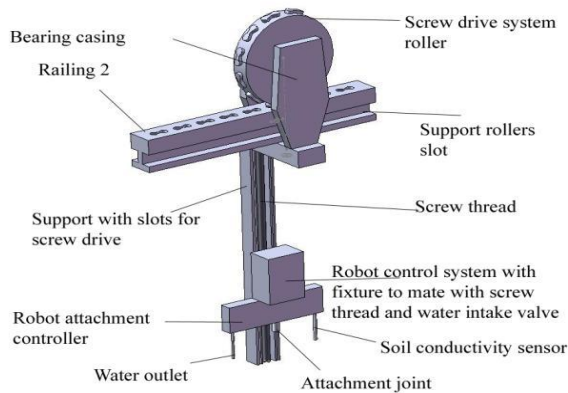

Fig 5: The vertical screw drive attached to the bearing case of the wheel moving on railing 2.

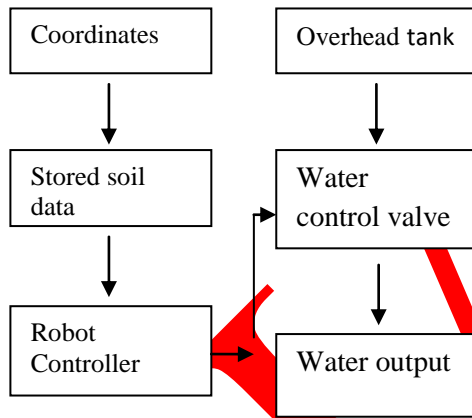

Fig 6: The block diagram of water flow in the robot system.

3.3 MOTORS AND CONTROLLERS

The linear drives have to be powered by DC motors fitted with optical encoders. Precise control of the motor would be required for exact positioning of the robot. The data from the optical encoders is to be stored in a computer to keep a constant record of the robots position. All precision agriculture related decisions of the robot depend on this coordinate data stored on the robots memory. The movement of railing 2 on railing 1 makes use of 2 DC motors, one mounted on each end of railing 2. The movement of the screw drive system on railing 2 makes use of one motor, while the screw drive system makes use of one motor. Appropriate linear drive controllers need to be used for the efficient and speedy performance of the linear drives. Also the oscillation of the suspended robot needs to be taken care of during the traversal of the robot. Various studies

on gantry robot controllers have been performed by Jones, J.F and Petterson [3] and Meressi [4]. These robot controllers are meant for industrial gantry systems and can be modified for the present system.

3.4 MATERIALS

Choosing the right material for the gantry frame forms an important task in the design of this robot. The material should be strong, light weight and inexpensive. It should also be able to withstand all weather conditions. Based on these constraints High Density Poly Ethylene would be an ideal material, although it costs more than steel. If steel is used, the long bars would sag under their own weight, which is to be avoided for smooth functioning of the robot.

3.5 PATH PLANNING

The robot should have a path planning program to minimize traverse movements. This saves energy used by the robot. The robot, before starting any operation should determine the most efficient path. For example minimizing movement on railing 1 reduces more energy as two motors are used for the robot to move on railing 1. Therefore, such optimizations should be planned by the robot.

3.6 POWER SOURCE

The robot will have to be powered by external AC supply through wiring. The AC power could be generated by diesel generator sets as power in rural areas in India is not reliable.

4. APPLICATIONS

One of the challenges of the robot would be its ability to adapt to unstructured environment. Although machine vision techniques are widespread these days, it would prove costly in an agricultural context. Therefore, through concepts such as crop planning, the robot structures the environment to suit its needs while maximizing yield.

4.1 CROP PLANNING

The robot first needs a precise measurement of the soil conditions of a farm. Soil conductivity sensors mounted on the robot measure the conductivity of the soil to determine the moisture content of the soil. As the robot traverses, conductivity sensor is inserted at constant intervals. After traversing the entire field, a map of the soil conductivities is constructed. Similar tests can

be performed to map the presence of various minerals based on the crops to be cultivated. From the map, with various constraints such as presence of moisture, minerals, optimum spacing of crop etc. put together, an array map of the crops is created. The robot then traverses the entire field and marks sowing points on the field. These are points where seeds are to be sowed during the sowing season. The robot also records the position of the sowing points for future operational uses.

4.2 PRECISION IRRIGATION AND FERTILIZER ADDITION

Fig 5 explains the method adopted to apply water to the crops according to the soil requirement at that position. Thus, a large volume of water resources would be conserved by applying the optimum amount of water. Based on the map of minerals created by the robot, right amount of fertilizers could be added to the water during precision irrigation of the crop. Thus, by adding the exact amount of fertilizer required for the particular soil location, the land is not degraded and yield is maximised. Thus accurate scientific methods are being implemented directly.

4.3 CROP AND SOIL MONITORING

Various agriculture-related sensors have been developed. Phytomonitoring sensors are capable of monitoring plant growth rates. Sensors are also used to monitor insect activity on crops. The soil data is also to be refreshed frequently as soil characteristics could change seasonally. These sensors can be fixed on the robot attachment joint and can be used throughout the field. The data collected could be used for immediate action to avert any crop failures.

4.4 DE WEEDING

De weeding is a wide research topic and lots of development has taken place in this field. Terrestrial robots have been used to perform de weeding operations. Various machine vision algorithms have been developed for weed recognition. Bakker et al [5] and use a machine vision enabled robot to carry out de weeding on a sugar beet farm. Watchareerueta et al [7] have developed image processing techniques to detect weeds in lawns, which could be applied for the above system with some modifications. Weed destruction can be carried out by positioning a pulsed high voltage device on the weed [6]. Electrical discharges burn the weed, thus destroying it. The electrical discharge device along with a camera mounted on the attachment joint can be used to de weed the entire farm.

5. CONCLUSION

A gantry robot that could be manufactured at a low cost could implement numerous precision agriculture related processes on a field with very less supervision. This could help in reducing input costs and increase agricultural outputs by maximising the crop yield of a given land. Dwindling water resources are of major concern today. Agriculture should do its part to conserve water resources. By applying adequate water to the crops using the system explained above, water could be conserved to a large extent compared to the conventional irrigation system. But one major concern would be the amount of power used by the robot system. Non conventional energy systems can be implemented to solve power problems of the robot system.

REFERENCES

- [1] Ancha Srinivasan; "Handbook of Precision Agriculture" – 2006
- [2] Perry, C., Pocknee, S.; "Precision Pivot Irrigation Controls to Optimize Water Application", NESPAL, The University of Georgia, Tifton GA
- [3] Jones, J.F.; Petterson, B.J.; "Oscillation damped movement of suspended objects"; Proceedings of the IEEE International Conference on Robotics and Automation; 24-29 April 1988 Page(s):956 - 962 vol.2; 1998
- [4] Meressi, "Modeling and control of a three dimensional gantry robot"; Proceedings of the 37th IEEE Conference on Decision and Control; Volume 2, Page(s):1514 - 1515 vol.2; 1998
- [5] Bakker, T.; et al; "An autonomous weeding robot for organic farming"; International Conference on Field and Service Robotics. - Port Douglas, Australia; 2005 - p. 580 – 591; 2005
- [6] Mizuno, A.; Tenma, T.; Yamano, N.; "Destruction of weeds by pulsed high voltage discharges"; Conference Record of the IEEE Industry Applications Society Annual Meeting, 1990., Page(s):720 - 727 vol.1; 1990
- [7] Watchareeruetai, U.; Takeuchi, Y.; Matsumoto, T.; Kudo, H.; Ohnishi, N.; "Computer Vision Based Methods for Detecting Weeds in Lawns"; IEEE Conference on Cybernetics and Intelligent Systems, June 2006 Page(s):1 – 6; 2006
- [8] Hamid Ali Abed Al-Asadi, "Temperature dependence of the noise characteristics of Multiisecton semiconductor lasers," Science Journal, vol. 7, No. 3, 2001.

- [9] Hamid Ali Abed Al-Asadi, "Linewidth characteristics of vertical cavity surface emitting lasers due to external optical feedback," Science Journal, vol. 8, 2001.
- [10] Boselin Prabhu S.R. and Sophia S., 'Modern cluster integration of advanced weapon system and wireless sensor based combat system', Scholars Journal of Engineering and Technology, 2(6A), 2014.
- [11] Boselin Prabhu S.R. and Sophia S., 'A review of efficient information delivery and clustering for drip irrigation management using WSN', International Journal of Computer Science and Business Informatics, 14(3), 2014.
- [12] Hamid Ali Abed Al-Asadi, "Linewidth characteristics of vertical cavity surface emitting lasers due to external optical feedback," Science Journal, vol. 8, 2002.
- [13] Hamid Ali Abed Al-Asadi, "Theoretical investigation of spectral linewidth properties of double fused 1.3 um MQW-VCA in reflection and transition modes," Tikrit Journal for Pure Science, vol. 8, No. 2, 2002.
- [14] Boselin Prabhu S.R. and Sophia S., 'Mobility assisted dynamic routing for mobile wireless sensor networks', International Journal of Advanced Information Technology, 3(3), 2013.
- [15] Boselin Prabhu S.R. and Sophia S., 'A review of energy efficient clustering algorithm for connecting wireless sensor network fields', International Journal of Engineering Research and Technology, 2(4), 2013.
- [16] Hamid Ali Abed Al-Asadi, "Vertical cavity amplifiers and its cavity length dependence the saturation power and quantum efficiency," Tikrit Journal of Pure Science, vol. 9, No. 2, 2003.
- [17] Hamid Ali Abed Al-Asadi, "Effects of pump recycling technique on stimulated Brillouin scattering threshold: A theoretical model," Optics. Express, Vol. 18, No. 21, pp. 22339-22347 Impact factor: 3.88, 2010.
- [18] Boselin Prabhu S.R. and Sophia S., 'Variable power energy efficient clustering for wireless sensor networks', Australian Journal of Basic and Applied Sciences, 7(7), 2013.
- [19] Boselin Prabhu S.R. and Sophia S., 'Capacity based clustering model for dense wireless sensor networks', International Journal of Computer Science and Business Informatics, 5(1), 2013.

[20] Hamid Ali Abed Al-Asadi, "Brillouin Linewidth Characterization in Single Mode Large Effective Area Fiber through the Co-Pumped Technique," International Journal of Electronics, Computer and Communications Technologies (IJECCCT), Vol. 1(1), pp. 16-20, 2010.

[21] Boselin Prabhu S.R. and Sophia S., 'An integrated distributed clustering algorithm for dense WSNs', International Journal of Computer Science and Business Informatics, 8(1), 2013.

[22] Boselin Prabhu S.R. and Sophia S., 'A research on decentralized clustering algorithms for dense wireless sensor networks', International Journal of Computer Applications, 57(20), 2012.

[23] Hamid Ali Abed Al-Asadi, "Analytical study of nonlinear phase shift through stimulated Brillouin scattering in single mode fibre with pump power recycling technique," Volume 13 Number 10, Journal of Optics. Impact factor: 1.99, 2011.

[24] Hamid Ali Abed Al-Asadi , "Architectural Analysis of Multi-Agents Educational Model in Web-Learning Environments," Journal of Emerging Trends in Computing and Information Sciences, Vol. 3, No. 6, June 2012.

[25] Boselin Prabhu S.R. and Sophia S., 'Hierarchical distributed clustering algorithm for energy efficient wireless sensor networks', International Journal of Research in Information Technology, 1(12), 2013.

[26] Boselin Prabhu S.R. and Sophia S., 'Real-world applications of distributed clustering mechanism in dense wireless sensor networks', International Journal of Computing Communications and Networking, 2(4), 2013.

[27] Haitao, Z, Shiwei, Z & Wenshao, B 2014, 'A clustering routing protocol for energy balance of wireless sensor network based on simulated annealing and genetic algorithm', International Journal of Hybrid Information Technology, vol. 7, no. 2, pp. 71-82.

[28] Han, L 2010, 'LEACH-HPR: An energy efficient routing algorithm for heterogeneous WSN', Proceedings of the IEEE International Conference on Intelligent Computing and Intelligent Systems, pp. 507-511.