

## DESIGN AND FABRICATION OF AUTOMOTIVE HYDRAULIC JACK SYSTEM FOR VEHICLES

\* Dr. Ramachandra C G, Krishna Pavana, Shivraj Shet and Venugopal Reddy

\*\* Virupaxappa B

\* Department of Mechanical Engineering  
Srinivas Institute of Technology  
Mangaluru, India

[ramachandra\\_cg@yahoo.com](mailto:ramachandra_cg@yahoo.com)

\*\* Department of Mechanical Engineering  
Dr M.V. Shetty Institute of Technology  
Moodbidri, India.  
[viru.komal@gmail.com](mailto:viru.komal@gmail.com)

### ABSTRACT

*Whenever any vehicles undergo a tyre failure, it becomes a very cumbersome task for the person to lift the vehicle from the ground level and lot of manual effort is required even though a jack is used. "Necessity is the mother of all inventions". This quote is a befitting to our project as we believe that man in today's world wants comforts and problem faced by people driving vehicles is more when the vehicle's tyre fails. Our projects main intention is to reduce the manual work and save time during the replacement of the failed tyre. To validate our point to overcome the difficulties of the above said problems, an inbuilt jacks have been designed and fabricated which is assembled on the vehicle. With the help of the existing brake pad and fluid arrangement of the braking system we incorporate the jack into to chassis of the vehicle with a set of unions, ball valves, master cylinder, five-way directional control valve, separated by a piping arrangements lifts the incorporated jack to action desired without raising any sweat of the driver.*

*Keywords: Automotive, Hydraulic Jack System: Design; Fabrication:*

### INTRODUCTION

In the recent past there has been a significant increase in the use of hydraulics in our industries [01]. The use of oil hydraulic systems as a means of power transmission in modern machines evolved a few decades earlier in the western world. But its applications in Indian industries are of comparatively recent choice and hence, there is great deal of urgency and importance to master the art of its applications and maintenance. Hydraulic systems are not extensively use in machine tools, material handling devices, transport and other mobile equipment, in aviation systems, etc.. At the moment there exists a big gap between the availability and requirement of skilled man power in this vital field of the modern engineering in India. To bridge the gap, it is essential that our design and application engineers and maintenance personnel from the lowest to the highest level are given extensive on job training so that operational efficiency and effectiveness of machineries using a hydraulic system as the prime source of power transmission can be maintained at an optimum level. Apart from the fluid power

system designer, a good maintenance and millwright mechanic should also have first hand theoretical knowledge to enable him to tackle practical problems encountered during installation, operation and maintenance of the hydraulic equipment. A jack is a mechanical device used to lift heavy loads or apply great forces. Jacks employ a screw thread or hydraulic cylinder to apply very high linear forces.

A mechanical jack [02] is a device which lifts heavy equipment. The most common form is a carjack, floor jack or garage jack which lifts vehicles so that maintenance can be performed. More powerful jacks use hydraulic power to provide more lift over greater distances. Mechanical jacks are usually rated for a maximum lifting capacity (for example, 1.5 tons or 3 tons).

#### A. *Conventional jack*

1. Screw jack
2. Scissor jack
3. Floor jack

##### 1. Screw jack



Figure 1. Screw Jack.

A jackscrew is a type of jack which is operated by turning a lead screw. It is also known as a screw jack, and is commonly used as car jacks. A jackscrew's compressive force is obtained through the tension force applied by its lead screw. An acme thread is most often used, and this thread is very strong and can resist the large loads imposed on most jackscrews while not being dramatically weakened by wear over many rotations. These types are self-locking, which makes them intrinsically safer than other jack technologies like hydraulic actuators which require continual pressure to remain in a locked position as shown in Figure 1.

## 2. Scissor jack

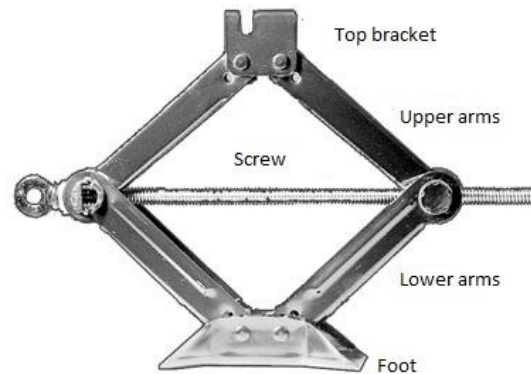

Figure 2. Scissor Jack.

A scissor lift (jack) or mechanism is a device used to extend or position a platform by mechanical means. The term 'Scissor' comes from the mechanism utilized which is configured with linked, folding supports in a crisscross 'X' pattern. The extension or displacement motion is achieved by applying of force to one of the supports resulting in an elongation of the crossing pattern. The force applied to extend the scissor mechanism may be hydraulic, pneumatic or mechanical (via lead screw or rack and pinion system).

## 3. Floor jack



Figure 3. Floor Jack.

An automotive floor uses hydraulic fluid to raise and lower heavy vehicles, usually personal cars and trucks. This type of floor jack is placed on the flat ground during use. Every automotive floor jack is rated for different weights, generally ranging from two to twenty tons. The hydraulic lift system can be used to easily lift heavy vehicles simply by pumping the long arm extending from the jack's body. In this way, the automotive floor jack allows the mechanic to change tires or to remove tires in order to check brake systems, examine undercarriage damage, or check exhaust pipes, among are other applications.

## B. Pallet jack

A Pallet Jack, also known as a pallet truck or pump truck, is a tool used to lift and move pallets. The front wheels are mounted inside the end of the forks, and as the hydraulic jack is raised, the forks are separated vertically from the front wheels, forcing the load upward until it clears the floor. The pallet is only lifted enough to clear the floor for subsequent travel. Some of the pallet jacks are as follows

### 1. Manual pallet jack



Figure 4. Manual Pallet Jack.

A manual pallet jack is a “truck” that is used to move a load from one place to another. The jack is placed on a pallet and the two times of the pallet jack slip into it. The times support the jack as it is moved to the desired place. Because it is on wheels, the load will roll easily along on a smooth surface such as a cement floor or asphalt. When the load has to be kept in a required place, the jack part of system lifts the load for proper placement on a rack or higher surface. Manual pallet jacks can be a boon to any business that needs to move heavy loads around their workplace.

### 2. Powered pallet jack



Figure 5. Powered Pallet Jack.

Powered pallet jacks, also known as electric pallet trucks, are motorized to allow lifting and moving of heavier and stacked pallets. These generally contain a platform for the user to stand while hauling pallets around a warehouse or loading/unloading trucks. The powered pallet jack is

generally moved by a throttle on the handle to move forward or in reverse and steered by swinging the handle in the intended direction. Some contain a type of dead man's switch rather than a brake to stop the machine should the user need to stop quickly or leave the machine while it is in use.

**C. Draw back with conventional jack**

- Requires more effort to operate.
- Wear of parts is more.
- Difficult to place the jack at the exact point of operation.
- Apparatus is heavy.
- Difficult to place the jack at the exact point of operation.

**D. Need for automotive inbuilt hydraulic jack system**

Today in this world of speed and motion, man's movement from place has been very rapid. Numerous ways of transport and travel have emerged owing to the needs of human being. This idea behind many of the innovation and inventions is to make human more comfortable and enable them to cope up with the pace of rapidly changing world. When such is the emphasis laid by man on time and comfort, it is of almost importance to reduce breakdowns and unnecessary halts during travels. A person acquainted with driving problem will certainly understand the difficulties and frustration due to breakdown of vehicle during journey. In automobile breakdown, not only is our precious time affected but also a great amount of money is wasted due to many factors that lead to breakdown. A few of them are suspension ill effects, engine problems and tyre damages. The most frequently encountered problem is that of tyre damage be it under inflated tyres or punctured tyres.

Due to god's grace, one may be fit enough to handle the conventional jack and change, the tyre. But one fact remains that all are alike in matter of strength. Today chunk of fair sex is doing a lot of driving. The change of tyres requires the use of jack, the most commonly adopted is the conventional screw jack. One has to place the jack under the vehicle and operate the lever i.e., physical efforts is required to operate the jack and lift the car. One could overcome these hardships, if he has provided himself with a lifting device that would operate automatically with least or no physical effort being into it and is time saving..

## **HYDRAULIC BRAKE SYSTEM**

The hydraulic brake is an arrangement of braking mechanism [03] which uses brake fluid, typically containing ethylene glycol, to transfer pressure from the controlling unit, which is usually near the operator of the vehicle, to the actual brake mechanism, which is usually at or near the wheel of the vehicle.

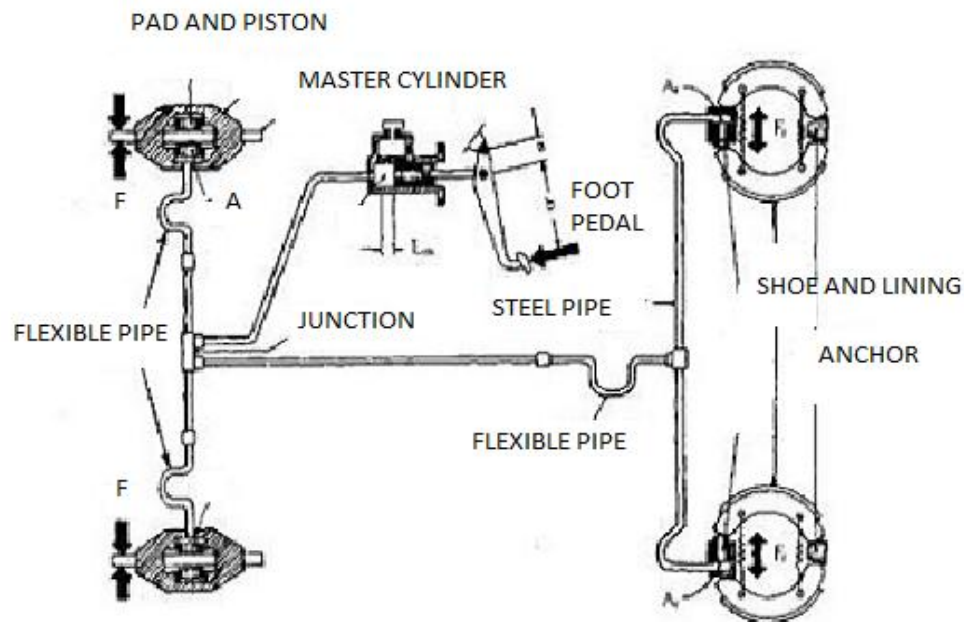

Figure 6. Hydraulic Brake System Set-Up.

### A. Principle

Hydraulic brakes work on the principle of Pascal's law which states that "pressure at a point in a fluid is equal in all directions in space". According to this law when pressure is applied on a fluid it travels equally in all directions so that uniform braking action is applied on all four wheels.

### B. Construction

The most common arrangement of hydraulic brakes for passenger vehicles, motorcycles, scooters, and mopeds, consists of the following:

- Brake pedal or lever
- A pushrod (also called an actuating rod)
- A master cylinder assembly containing a piston assembly (made up of either one or two pistons, a return spring, a series of gaskets/ O-rings and a fluid reservoir)
- Reinforced hydraulic lines
- Brake caliper assembly usually consisting of one or two hollow aluminium or chrome-plated steel pistons (called caliper pistons), a set of thermally conductive brake pads and a rotor (also called a brake disc) or drum attached to an axle.

### C. Operation

Hydraulic brakes transfer energy to stop an object, normally a rotating axle. In a very simple brake system, with just two cylinders and a disc brake the cylinders could be connected via tubes, with a piston inside the cylinders. The cylinders and tubes are filled with incompressible oil. The two cylinders have the same volume, but different diameters, therefore different surface

areas. The one with the smallest diameter is called the master cylinder. The spinning disc brake will be placed down at the piston with the larger surface area. Let us say that the diameter of the master cylinder is half the diameter of the slave cylinder, so the master cylinder has a surface area which is four times smaller. Now, if the piston in the master cylinder is pushed down 40 mm, with 10 N of force, the slave piston will then move 10 mm, with a force of 40 N. This force can be further multiplied by adding a lever connected between the master piston, a pedal, and a pivot point. If the distance from the pedal to the pivot is three times the distance from the pivot to the connected piston, then it multiplies the pedal force with a factor of 3, when pushing down on the pedal. Now, if we push down on the pedal 120 mm with 10 N of force, 30 N will then be applied to the master piston, and the slave piston will then push 10 mm against the brake pad, with a total force of 120 N.

## DESIGN OF AUTOMATIC HYDRAULIC SYSTEM

Hydraulic systems rely on the fact that liquid are virtually incompressible and pressure applied where in the fluid is transmitted in all directions as in fig. Operated by pressure, it exerts a force which proportionally greater than that applied to the first piston but distance moved by second piston will be correspondingly less. If, for instance, the second piston has three times the area of the first piston, it will exert three times the force through one third of distance travelled by the first piston. All present day cars are equipped with hydraulic break system. Using the master cylinder [04] of the hydraulic brake system, an inbuilt hydraulic jack system. Here in four hydraulic jacks are provided at suitable places near the four wheels of the car. A manually operated non return valve is provided on the fluid line from master cylinder to five-way plug valve can be operated manually, ball valve is provided so the fluid does not return back into the master cylinder. The master cylinder is being used in the hydraulic brake system of the car; the non return check valve is manually opened so that it allows the fluid the fluid to go back into the master cylinder when pedal of the brake is released.

### A. Master Cylinder

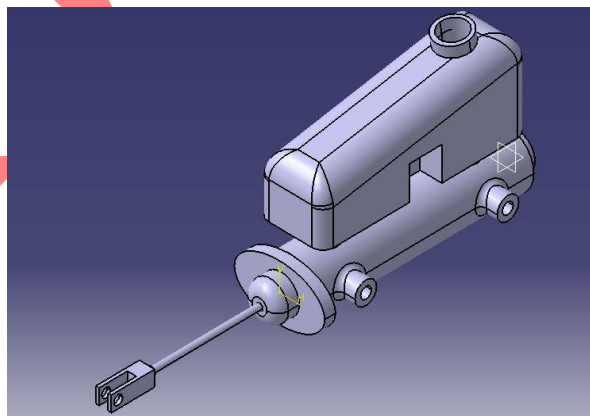

Figure 7. Master Cylinder.

The master cylinder can be rigidly named as heart of the hydraulic braking system [07], because the pressure necessary for operating the brakes as well as the hydraulic jacks is

developed in this cylinder. There are two main chambers viz. the fluid reservoir and compression chamber in which the piston operates. The fluid in the reservoir compensates for any change in the fluid volume in the pipelines due to temperature variations and to some extent due to leakage. To prevent leakage there are rubber seals on both ends of the piston in the compression chamber. The reduced diameter region of the piston is always surrounded by the fluid. A rubber boot covers the push rod end of the cylinder to prevent the dirt from entering inside. Towards the brake lines side of the compression chamber, there is a fluid check valve with a rubber cup inside. It serves to retain the residual pressure in the brake lines even when the brakes are released.

**B. Single acting hydraulic cylinder**

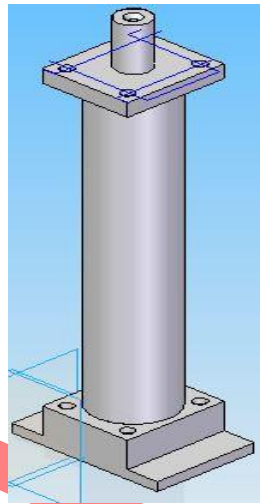

Figure 8. Single Acting Hydraulic Cylinder.

Hydraulic cylinders get their power from pressurized hydraulic fluid [06], which is typically oil. The hydraulic cylinder consists of a cylinder barrel, in which a piston connected to a piston rod moves back and forth. The barrel is closed on each end by the cylinder bottom (also called the cap end) and by the cylinder head where the piston rod comes out of the cylinder. The piston has sliding rings and seals. The piston divides the inside of the cylinder in two chambers, the bottom chamber (cap end) and the piston rod side chamber (rod end). The hydraulic pressure acts on the piston to do linear work and motion. Flanges, trunnions, and/or clevises are mounted to the cylinder body. The piston rod also has mounting attachments to connect the cylinder to the object or machine component that it is pushing.



### C. Five-way directional control valve

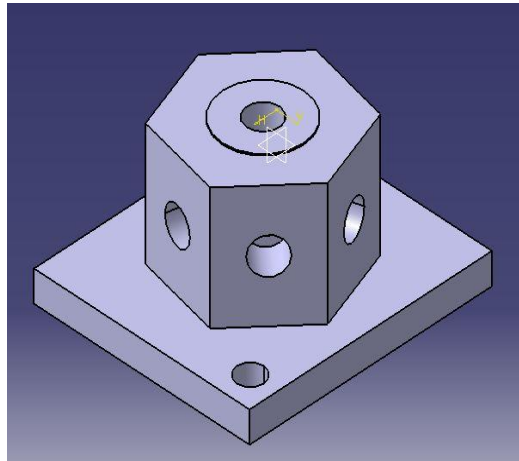

Figure 9. 5-Way Directional Control Valve.

The body of the valve is made of carbon steel or cast iron [07]. The exterior and interior are cylindrical in shape. The interior is well ground for good seating of the plug. A hole in the body cover or plate, which is placed below it and is fastened by screw after the plug is placed in the body. It has an inlet port on its circumference at the top. The body plate has markings indicating the direction of the part lead i.e., right front jack, left front jack, right rear jack, left jack and brakes. The operating handle is fixed to the plug by threads and a check nut so as to fix the handle in the direction of outlet part of the plug. This means that when the handle is in the directions of the left front jack marking of the cover plate. It will operate the left front jack, when the brake pedal is operated.

### D. Non-return valve

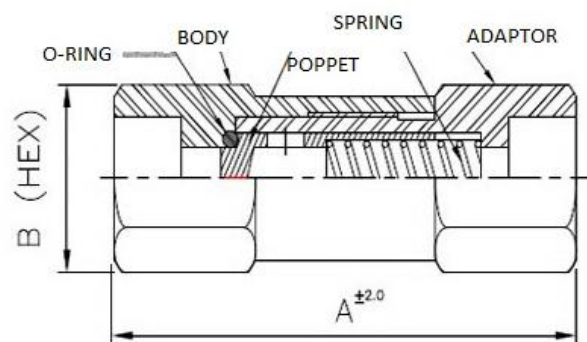

Figure 10. Non-Return Valve.

A check valve, clack valve, non-return valve or one-way valve is a mechanical device, a valve, which normally allows fluid (liquid or gas) to flow through it in only one direction. Check valves are two-port valves, meaning they have two openings in the body, one for fluid to enter and the other for fluid to leave. There are various types of check valves used in a wide variety of applications. Check valves are often part of common household items. Although they are available in a wide range of sizes and costs, check valves generally are very small, simple,

and/or inexpensive. Check valves work automatically and most are not controlled by a person or any external control; accordingly, most do not have any valve handle or stem. The bodies (external shells) of most check valves are made of plastic or metal.

### E. Design and Calculations

#### 1. Design of Hydraulic Jack System

Unaided weight of the car = 1200 kg

Weight of five passengers = 500 kg

Weight of luggage = 100 kg

Total weight = 1200 + 500 + 100 = 1800 kg = 17658 N

Diameter of the master cylinder = 2.5 cm = 25 mm

Area of master cylinder =  $\frac{\pi}{4} d^2 = \frac{\pi}{4} (25)^2$

$A_1 = 490.87 \text{ mm}^2$

#### Specifications of hydraulic cylinder:

Outer diameter of cylinder = 60 mm

Inner diameter of cylinder = 50 mm

Diameter of the piston = 50 mm

#### Materials:

1. Stainless steel
2. Galvanized iron (GI) pipe.

#### Design of hydraulic unit:

By Pascal's law,

=

$F_1 = P \cdot A_1$

$A_2 = \frac{\pi}{4} d_p^2$

Where,  $d_p$  = diameter of the piston = 50 mm

$A_2 = \frac{\pi}{4} (50)^2 = 1963.49 \text{ mm}^2$

$F_1 = P \cdot 490.87 = 4414.48 \text{ N}$

Pressure exerted,  $p = \frac{F_1}{A_1} = \frac{4414.48}{490.87} = 900.91 \text{ N/cm}^2$

#### Thickness of cylinder (t):

$$t = r_1 \left[ \sqrt{\frac{f_t + p}{f_t - p}} - 1 \right]$$

$r_1 = 1.25 \text{ cm} = 12.5 \text{ mm}$

$f_t = 800 \cdot 9.81 \text{ N/cm}^2$

$$t = 1.25 \left[ \sqrt{\frac{((800 \cdot 9.81) + 900.91)}{((800 \cdot 9.81) - 900.91)}} - 1 \right] = 0.649 \text{ cm} = 6.49 \text{ mm} = 6.5 \text{ mm}$$

#### Design of piston rod:

$$\text{Force on piston rod (F)} = \frac{\pi}{4} \cdot d_p^2 \cdot P = \frac{\pi}{4} \cdot 5^2 \cdot 900.91 = 17689.32 \text{ N}$$

Also force,

$$F = \text{stress} * \text{area} = f_c * \frac{\pi}{4} * d_h^2$$

$$d_h^2 = \frac{4 * F}{\pi * f_c} = \frac{4 * 17689.32}{\pi * 600 * 9.81} = 3.958 \text{ cm}^2$$

$$d_h = 1.989 \text{ cm} = 2 \text{ cm} = 20 \text{ mm}$$

for safe design,  $d_h = 3 \text{ cm} = 30 \text{ mm}$

### Design of fork pin:

Load on pin = force acting on piston rod & the force pin is in double shear

$$f_s = \frac{F}{2A}$$

$$A = \frac{F}{2f_c} = \frac{17689.32}{2 * 450 * 9.81} A = 2.072 \text{ cm}^2$$

$$A = \frac{\pi}{4} * d_r^2$$

Where,  $d_r$  = rod diameter

$$d_r^2 = \frac{4A}{\pi} = \frac{4 * 2.072}{\pi} \quad d_r = 1.624 \text{ cm} = 16 \text{ mm}$$

### Design of flat end cover:

$t_c$  = thickness of end cover

$$f_t = \frac{F}{A}$$

$$A = \frac{F}{f_t} = \frac{17689.32}{800 * 9.81} = 2.33 \text{ cm}^2$$

$$A = d_p * t_c$$

$$t_c = \frac{A}{d_p} = \frac{2.33}{5} = 0.466 \text{ cm} = 5 \text{ mm}$$

### Lift per stroke:

$d$  = diameter of plunger = 25 mm

Equating volume of fluid displaced,

We have,

$$\frac{\pi}{4} * d^2 * l = \frac{\pi}{4} * d_p^2 * h$$

$$h = \frac{d^2 * l}{d_p^2} = \frac{2.5^2 * 2.5}{5^2} = 0.625 \text{ cm} = 6.25 \text{ mm}$$

**Design of Helical Springs:** Design procedure [05] for helical compression spring of circular cross-section are

### Diameter of Wire:

$$\text{Shear Stress, } \tau = \frac{8FDk}{\pi d^3}$$

$$F = 300 * 9.81 = 2943 \text{ N}$$

$$\tau = 30\% \text{ of the } U_{st}.$$

$$= \frac{30}{100} * 1725 = 517.5 \text{ N/mm}^2$$

$$\text{Wahl's stress factor, } k = \frac{4c-1}{4c-4} + \frac{0.615}{c}$$

$$\text{Assume, } c = 4, \quad c = \frac{D}{d}, \quad D = c * d = 4 * d$$

$$k = \frac{4(4)-1}{4(4)-4} + \frac{0.615}{4} = 1.404$$

$$517.5 = \frac{8*2943*4d*1.404}{\pi d^3}$$

$d = 9.018 \text{ mm}$ , Standard diameter of wire,  $d = 9 \text{ mm}$ .

#### Diameter of coil:

$$c = \frac{D}{d}, \quad 4 = \frac{D}{9}$$

Mean diameter of coil,  $D = 36 \text{ mm}$ .

Outer diameter of coil,  $D_o = D+d = 36+9 = 45 \text{ mm}$

Inner diameter of coil,  $D_i = D-d = 36-9 = 27 \text{ mm}$

#### Number of coils (or) turns:

$$\text{Deflection, } y = \frac{8FD^3 i}{Gd^4}$$

From the DDHB,  $G = 78450 \text{ MN/m}^2 = 78450 \text{ N/mm}^2$

$$25 = \frac{8*2943*36^3*i}{78450*9^4}$$

$i = 11.71$ , Number of active turns,  $i = 12$ .

#### Free length:

$$l_o = (i+n) d + y + a$$

Clearance,  $a = 25\%$  of maximum deflection

$$l_o = \frac{25}{100} * 25 = 62.5 \text{ mm}$$

Assume squared and ground end,  $n = 2$

$$l_o = (12+2) 9 + 25 + 6.25 = 157.25 \text{ mm}.$$

#### Stiffness (or) rate of spring:

$$F_o = \frac{F}{y} = \frac{2943}{25} = 117.72 \text{ N/mm}$$

#### Pitch:

$$p = \frac{l_o - 2d}{i} = \frac{157.25 - 2*9}{12} = 11.6 \text{ mm}$$

#### Total length of wire:

$$L = \pi D_i i = \pi * 36 * 12 = 1357.17 \text{ mm}.$$

#### F. Fabrication details

The following are the list of required components fabricated for Automated Hydraulic System for vehicles.

1. Hydraulic cylinder or jack (4 No.): Cylinder barrel, Cylinder base or Cap, Cylinder head, Piston, Piston rod, Rod gland
2. Five-way directional control valve (1No.)
3. Master cylinder (1 No.)
4. Non return valve (1 No.)
5. Ball valve (5 No.)
6. Hydraulic fitting and pipes
7. Chassis.

The assemble view of the fabricated components are shown in Figure 11 and 12.

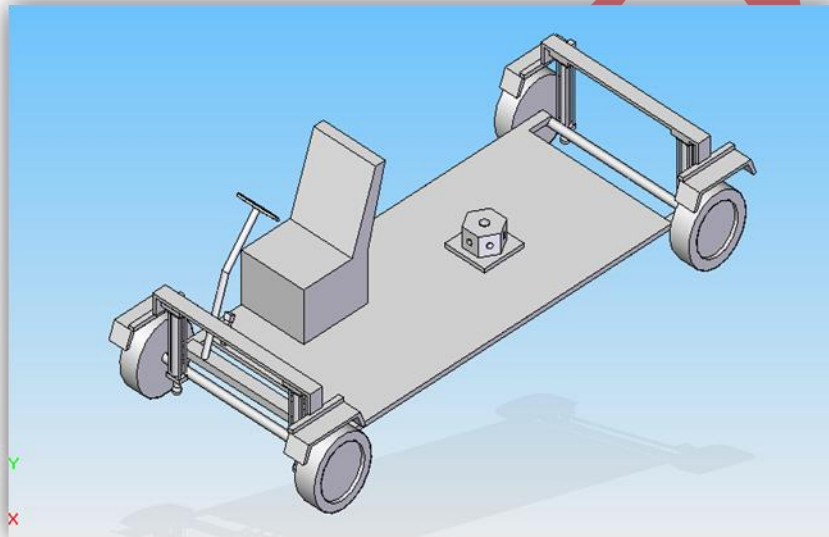

Figure 11. 3-D View of the Automatic Hydraulic Jack System.

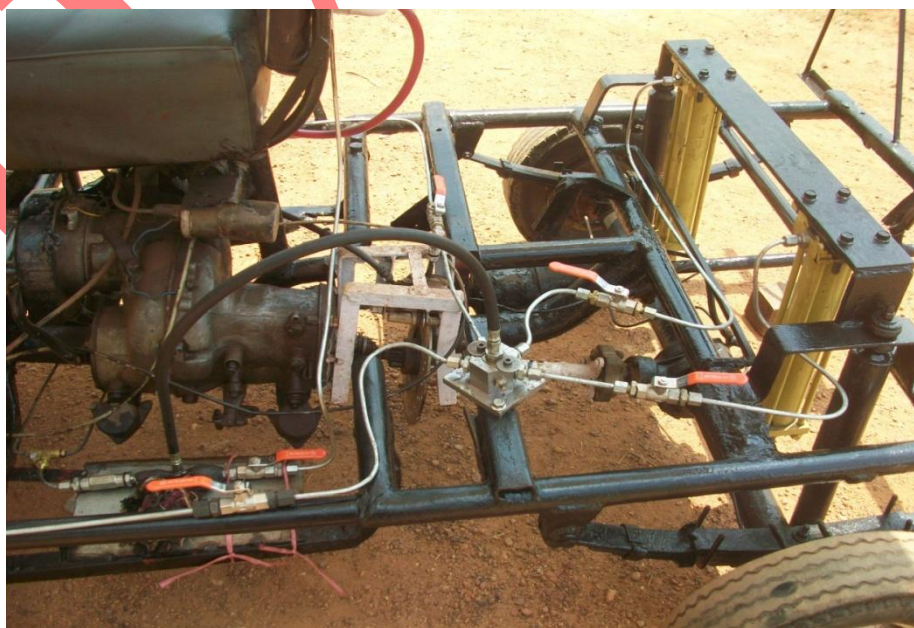

Figure 12. Photo of the Automatic Hydraulic Jack System.

## CONCLUSIONS

The challenges that a new product faces is not just to meet social necessities but also to build a product that is worth as regards of its cost and utility. Pessimistic dorks predict that it could not be done but this gloomy out looks obviously neglect the inventive genius of the building engineers. Things changes quietly without warning which makes old rules to lose their meaning. Just yesterday this conventional jack was the most widely used, tomorrow it will be obsolete. Enter the bright new innovative idea, for your lifestyle and status, the grandeur of “Design and Fabrication of Automotive Inbuilt Hydraulic Jack System” is the end product of a concerted process in designing aesthetics, value edition and comfort engineering and high grade materials backed by a hard core service team. Yet some of the ingredients remain the same. With these extra cost owners of car can get facility, which they are very happy to own of their cars. Though this system has been designed keeping in view ambassador car, but it can be used for other cars also with slight modification. The estimated costs are for making prototype but, if it is mass produced the cost can be considerably reduced. It is very convenient system and its use will be very popular if any entrepreneur’s introduced the system in the market.

## REFERENCES

- [1] Anthony Esposito, “Fluid power with applications”, Fifth edition Pearson education, Inc.2000.
- [2] Vickers, “Industrial hydraulics manual”, second edition 1989.
- [3] Q.S. Khan, “Study of hydraulic seals”, Fluid Conductor and Hydraulic Oil, Volume-6, 1998.
- [4] Balaveera Reddy and K. Mahadevan, “Design Data Hand Book”, Third Edition, CBS publications, 1987.
- [5] R.S. Khurmi and J.K Gupta, “Machine design”, S. Chand publications updated edition 2005.
- [6] [http://en.wikipedia.org/wiki/Hydraulic\\_cylinder](http://en.wikipedia.org/wiki/Hydraulic_cylinder).
- [7] [http://en.wikipedia.org/wiki/Master\\_cylinder](http://en.wikipedia.org/wiki/Master_cylinder).
- [8] [http://www.hitech.in/control\\_valves](http://www.hitech.in/control_valves).